



CHARGE - AH - MONITOR

AH-01 is a microcontroller based unit, which is used for monitoring the charge (Ampere Hour or Ampere Minute) transferred to a load / battery. The unit can be used to accurately control the quality of various processes such as battery plate formation, electro plating, electro etching, pcb manufacturing etc. The unit provides a change over relay contact, which operates when a set amount of charge is transferred to the process. The unit is user friendly and provides field setting for charge limit and shunt ratings. The unit has a non volatile memory to store the reading and settings, case of power failure. Remote reset facility is provided.

FEATURES

- A settable low charge alarm
- Display of the charge as AH and AM
- Field Setting of the charge limit.
- Field setting of the shunt rating.

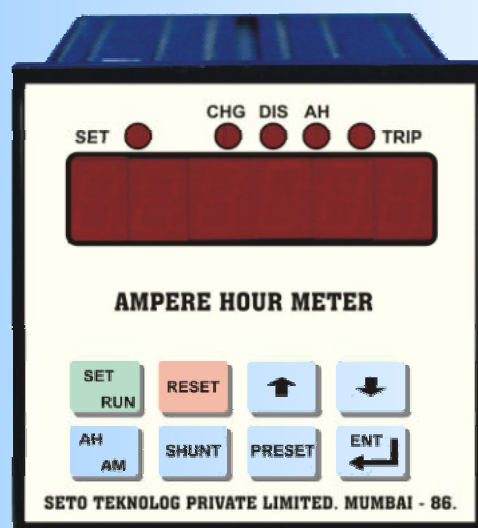

SPECIFICATIONS

- **Input** : 0 – 100 mV dc.
- **Display** : 6 digit, LED.
- **Supply** : 24 V, 48 V, 110 V & 220 V DC or AC
- **VA Rating** : 2 VA max
- **Settings**
 1. Shunt Current (1 to 9999 Amps in steps of 1 Amp).
 2. Charge Limit (1 to 9999 AH or 1 to 9999 AM)
- **Indications**
 1. All Settings.
 2. Charge
- **Protection** : Code Number to enable the Editing of settings.
- **Output** 1 Relays(5 Amp, 230 V AC / 28 V DC).
Charge limit
- **Dimensions** 96 x 96 x 150 mm Front panel mounting

BLOCK DIAGRAM

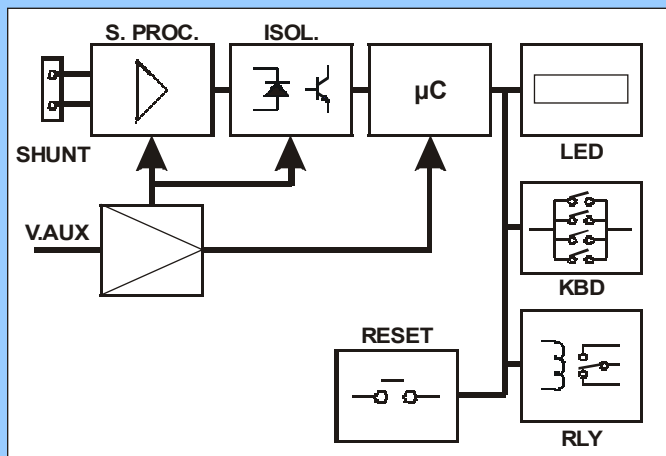

OTHER PRODUCTS

- Supervisory Remote Control & Data
- Acquisition Systems – Total turnkey
- Remote terminal Units (RTU).
- Micro RTU.
- Microprocessor Based Equipments – MCB Monitors, Beetle Monitors, Temperature Scanner etc.
- Custom Built Electronic Equipments.
- Digital A.C. Ammeter
- Digital A.C. Voltmeter
- Digital Volt, Amp, & Watt Meter – class 0.5 / 0.2
- Position Indicating Transducers.
- Static Energy Meters.
- Digital Flow Meters.
- Digital Power Monitor Cum Controllers.



SETO TEKNOLOG PRIVATE LIMITED.

106/406, Hill View Ind. Estate, Ghatkopar (W), Mumbai-400 086.
Phone : 91-22-2500 7385 / 5595 1888 ♦ Fax : 91-22-2500 7497
email : seto@vsnl.com ♦ Website : www.seto.co.in